

Beancat[®]

SERVICE MANUAL

BC-250

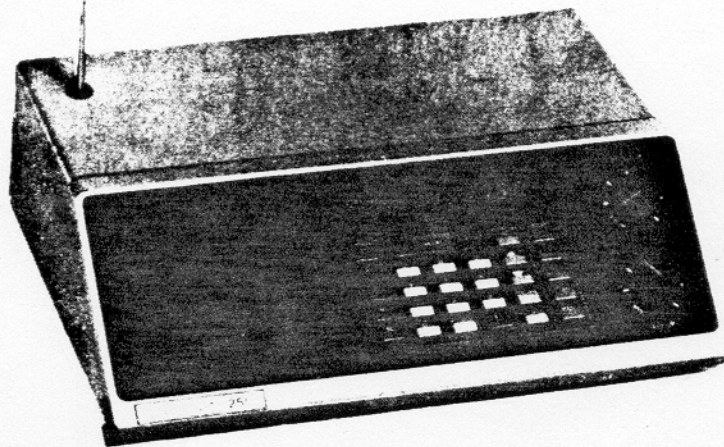

uniden[®]

CORPORATION OF AMERICA

**6345 CASTLEWAY COURT
INDIANAPOLIS, INDIANA 46250**

BC-250 SERVICE MANUAL

SPECIFICATIONS	1
CIRCUIT DESCRIPTION	
I. GENERAL	2
II. a) VHF	4
b) UHF	5
c) VCO	5
d) Track Tuning	7
III. I.F.	9
IV. a) Audio11
b) Squelch11
c) Power Supply14
V. SYNTHESIZER	
a) Mixer15
b) Prescaler16
c) Divide by N16
d) Phase Comparator17
e) Loop Filter.17
f) Bandswitching.18
g) 433KHz clock/ <u>+26</u> volts19
VI FEATURE BOARD	
a) Keyboard Entry and Display20
b) Hex Latch22
c) Memory22
d) Search/Time23
ALIGNMENT PROCEDURE24
SYMPTOM AND CURE AIDS27
PARTS LIST33

REFERENCE DOCUMENT LIST

			<u>Page</u>
(Fig. 1)	XB963	BC-250 Block Diagram	(3)
(Fig. 2)	XA941	Tuning Voltage	(6)
(Fig. 3)	XA756	NB53101 (IC3)	(8)
(Fig. 4)	XB965	Squelch Circuitry Schematic	(10)
(Fig. 5)	XA757	Hex Latch (IC201)	(21)
	XD354	Schematic, Radio Board	(28)
	XD358	Schematic, Feature Board	(29)
	XW978	Parts Placement Diagram	(30)

TECHNICAL SPECIFICATIONS*

Size: 10 3/4" Wx3 1/2" H x 8" D
 Weight: 5 lbs.
 Cabinet: Vinyl-clad steel
 Power requirements: 117Vac, 20W 13.8Vdc, 9W
 Antenna: Telescoping whip (supplied)
 Connector provided for external antenna (50-70 ohms)
 Clock: Crystal-controlled; LED display of hours, minutes, seconds, Keyboard-resetable
 Frequency Coverage: Low Band 32 - 50MHz
 Amateur 146 - 148MHz
 High Band 148 - 174MHz
 UHF Band 420 - 470MHz
 UHF-T Band 470.0125-512.0125MHz
 RF Sensitivity: .4 microvolts 30-174MHz
 (+5KHz deviation, 12db SINAD) .8 microvolts 420-51MHz
 Squelch Sensitivity: .3 microvolts 30-174MHz
 .6 microvolts 420-512MHz
 IF selectivity: -60db @ +25KHz
 Scan/Search Speed: Selectable 5 or 15 channels per second
 Scan/Search Delay: Selectable 0 or 2 seconds
 Audio output: 2 Watts RMS, 8 ohms.10% THD (max.)
 Auxiliary Output: Will switch 500 ma.d.c. (max.sink) external load
 Front Panel Controls: Volume (on/off)
 Squelch (Auto Squelch)
 Display
 Keyboard
 Speaker
 Rear Apron Connectors: 12Vdc
 117Vac
 External Antenna
 External Speakers (2 jacks)
 Auxiliary Control Terminal
 Ground Terminal

*Specifications are typical and subject to change without notice

GENERAL

Figure 1 is a block diagram of the Bearcat 250 receiver. From a single antenna input, Low/High VHF (32-50MHz - 146-174MHz) and UHF frequencies (420-512MHz) are coupled through track-tuned amplifier and mixer stages to a common I.F. (10.85MHz). A second oscillator at 10.4MHz is used for mixing down to a 450KHz second I.F. which is limited and demodulated. The recovered audio is coupled to the audio amplifier and also filtered for activation of the noise-squelch circuit.

The local oscillator signal is derived from a phase-locked-loop synthesizer. The VCO (Voltage-Controlled Oscillator) frequency is divided down by a programmable counter which is preset from memory and compared to a reference frequency. Any frequency or phase difference produces a correction signal to change the VCO tuning voltage. This tuning voltage then forces the VCO to oscillate at the frequency required for the counter to produce an output that is in phase with the reference frequency. Thus, changing the modulus of the counter will change the frequency of the VCO. In order to increase the range of the counter, it is prescaled by 15 to 16 on all bands and the VCO is mixed with a 133MHz oscillator on HIGH Band and VHF to achieve the higher frequencies required. For UHF, the VCO is then tripled to obtain its proper local oscillator frequency.

The frequency program is entered from a decimal keyboard into a microprocessor where it is multiplexed to drive the display and decoded to enter the proper binary code in memory to control the synthesizer.

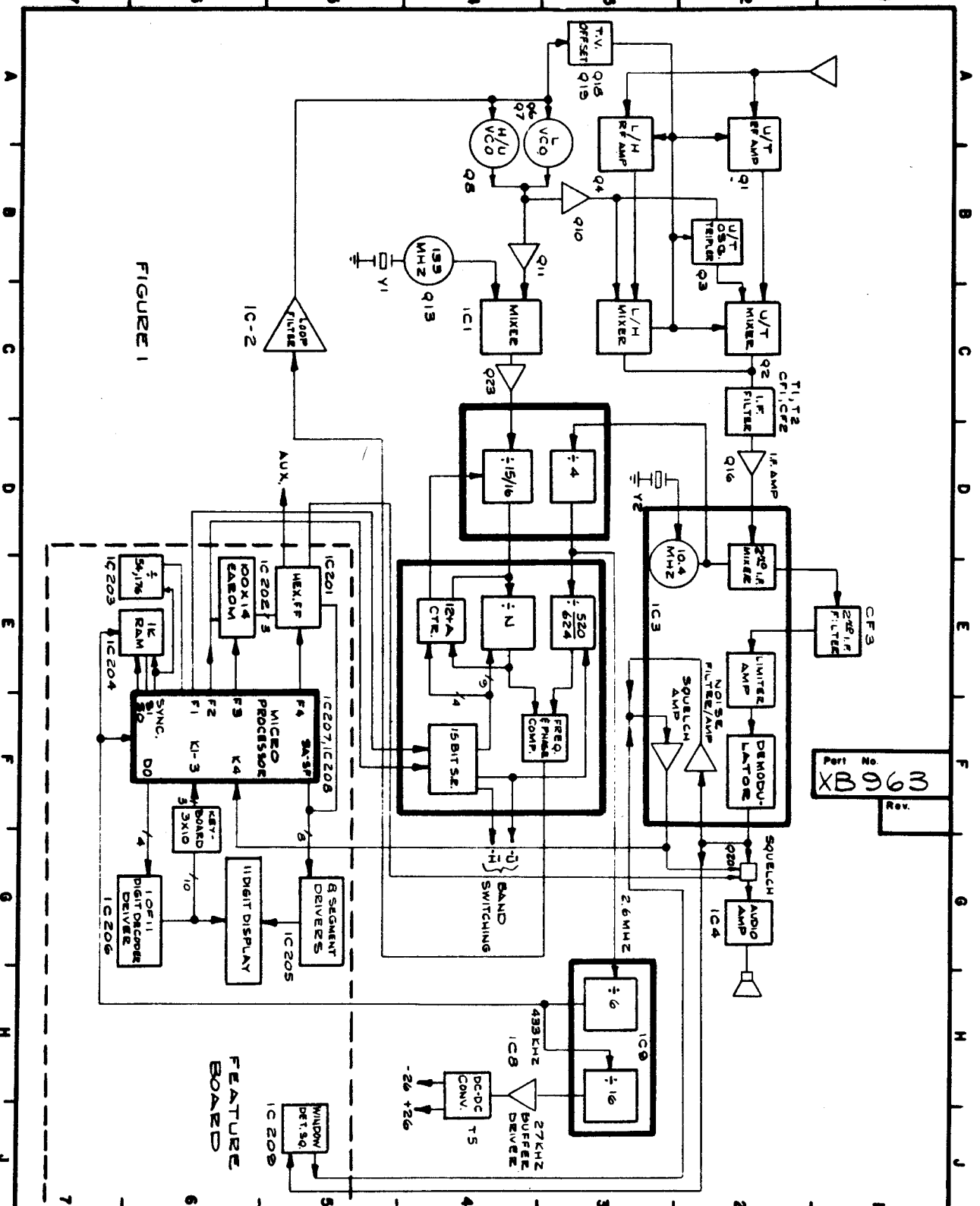

FIGURE 1

Part No. **XB963**

FEATURE BOARD

Rev. EN	Description & Location	Int. date
<p>This information is confidential and proprietary to Messco Corporation of Indiana and shall not be divulged or used in the detriment of Messco Corporation of Indiana without written permission.</p>		
<p>Part. Models: BC 250</p>		
Appr.:	Scale:	DATE:
Designer:	DATE:	DATE:
Dev. Eng.:	DATE:	DATE:
<p>Tolerances unless otherwise specified: 2 Piece dec. ± .010 3 Piece dec. ± .005 Fractions ± 1/64 Angles ± 1/2°</p>		
<p>EA ELECTRONICS Part of Messco Corp. of Ind. Columbus, Ind. 47524</p>		
Title:	BC 250	
Part No.:	XB 963	
Rev.:	Res.	

SECTION II

II. a) VHF

An L or H BAND signal enters the receiver through the antenna. Coil L1 attenuates frequencies that are below the low band, while diodes D1 and D2 limit the amplitude of very strong signals that would cause overload. The impedance looking into C1 from the antenna is relatively high, so the signal proceeds down to the parallel combination of C18 and L8. This circuit becomes parallel resonant in the U BAND and acts as a high impedance trap to keep UHF frequencies off the gate of Q4. Now L8 is a 2 turn coil which is practically a short circuit to the L & H BAND frequencies, so they pass directly to the gate of Q4. If a LOW BAND frequency is being received, the tank circuit for the gate consists of L9, L10, C21, and VVC4. Transistor Q4 is a dual gate, N-channel MOS FET, which is the R. F. stage. The tank circuit for the output consists of L11, L12, C25, and VVC5 for low band signals. The signal from Q4 is transferred through C28 to Q5, another dual gate MOS FET, which acts as the mixer stage. The local oscillator signal is supplied through C27 to the second gate of Q5. The oscillator frequency is 10.85MHz lower than the signal frequency*, so the output frequency is 10.85MHz. The load on the drain of Q5 is tuned to that frequency.

* 10.8 MHz Lower on 10.8 1F (400 KHz 2nd. 1F) Version

The signal flow for a HIGH BAND input from the antenna is the same as for the LOW BAND except diodes D3 and D4 are turned on by the band switching circuitry. This shorts out L10 and L12 respectively, causing the inductance in the tank circuits to be reduced to the lower values needed for operation at the higher frequencies.

II.b) UHF

A U BAND signal at the antenna is coupled through C2 to a tank circuit consisting of VVC1, C2, L2, and L3. It is tapped down to a lower impedance and then passed on through C3 to Q1, the R.F. amplifier. This is a grounded base stage and the output tank consists of VVC2, C5, L5, and L6. Once again the impedance is tapped down, and passed on to the base of the next stage, Q2, a bipolar transistor which is the mixer. The local oscillator signal is also supplied to the base of Q2 through capacitor C9. The load of this stage is tuned to the 1st I.F. frequency (currently 10.85MHz). Q3 is the U/T Tripler.

II. c) V.C.O.

The Voltage Controlled Oscillator for HIGH and UHF BANDS in Q8 with the frequency determined by L14, C32, C33, and VVC7. These components permit the control voltage on VVC7 through R31 to tune the oscillator through the required local oscillator frequency range (135-167MHz) required for HIGH and UHF BANDS.

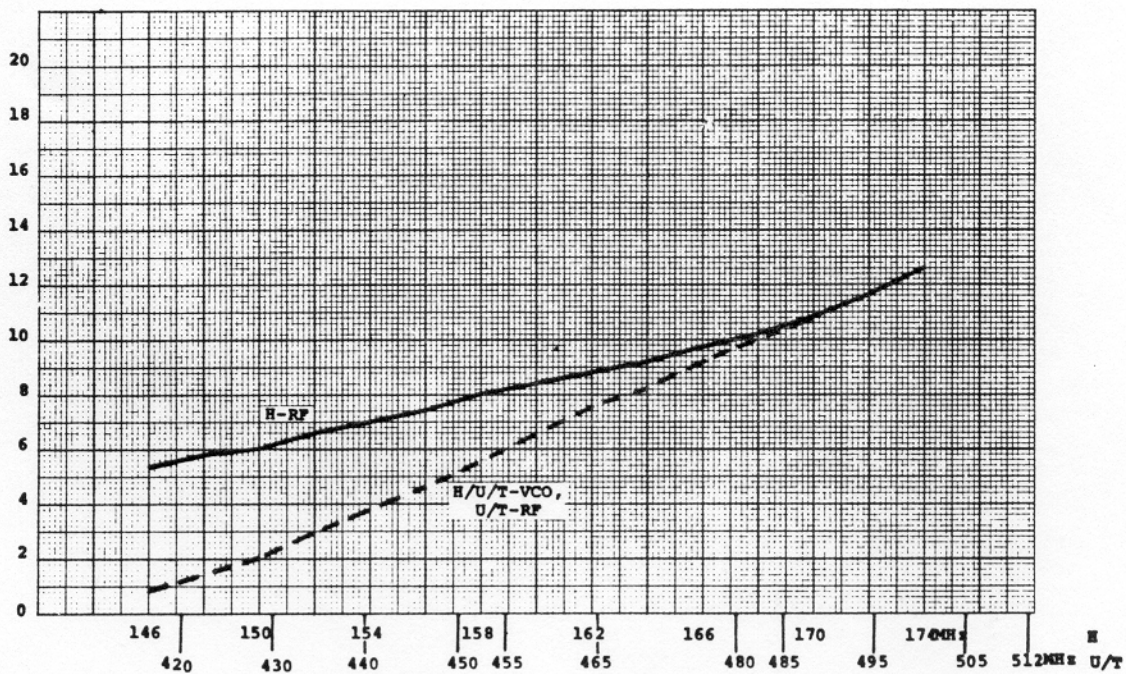
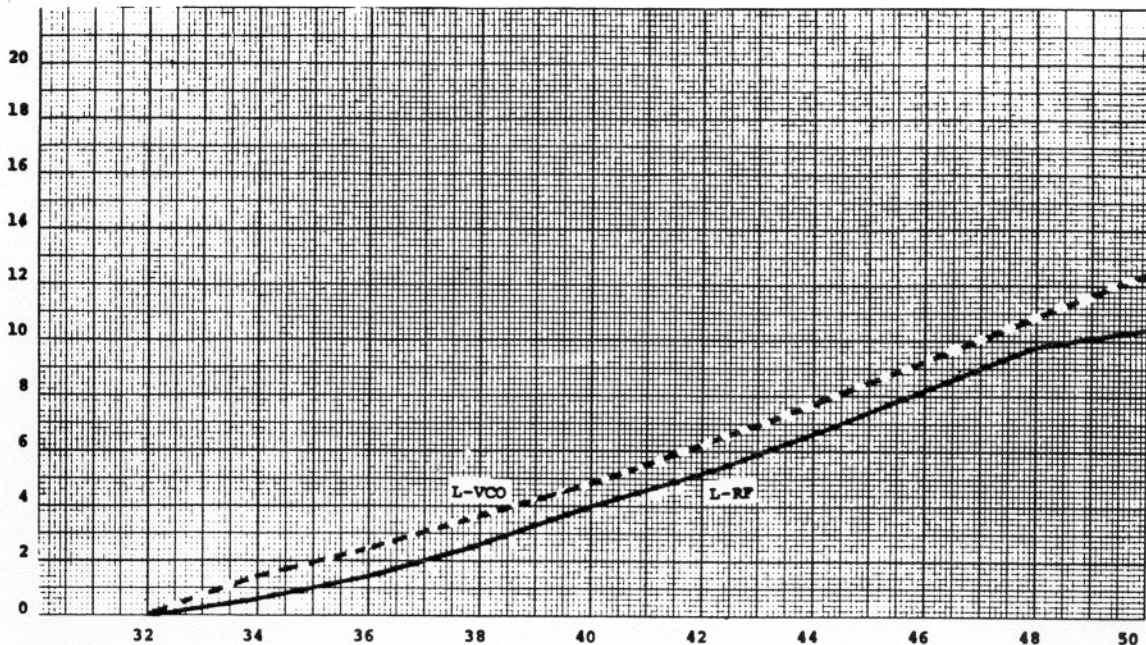

FIGURE 2
BC-250 TUNING VOLTAGE

In Low Band, the collector Q12 is HIGH disabling Q8 which allows operation of Q6 and Q7 (LOW BAND VCO). The tank circuit consists of L13, C29, and VVC6 with feedback provided by C28. These provide the required LOW BAND oscillator range from the control voltage supplied through R24.

The Frequency vs. Voltage curves produced by VCO's are shown in Figure 2.

II. d) TRACK-TUNING

The Tuning Voltage versus Frequency Curves, shown in Figure 2, produced by both VCO ranges, are used as the reference for track-tuning all R-F circuits.

The H/U/T VCO voltage curve is applied directly through R76 to VVC's 1, 2, and 3 to tune the U/T circuits to resonance for each frequency.

In High Band, the voltage required to tune the RF circuits is more than the voltage produced by the H/U/T VCO. Therefore, Q18 is turned on in High Band to provide a positive offset current through R71 and R11 to produce the required HIGH BAND tracking curve as shown in Figure 2.

For Low Band, the voltage required for tracking the RF circuits is less than the Low Band VCO voltage. Q19 is used to sink current through R75 to drop voltage across R76 to produce the L Band tracking curve shown in Figure 2.

Part No. **XA 756** Rev.

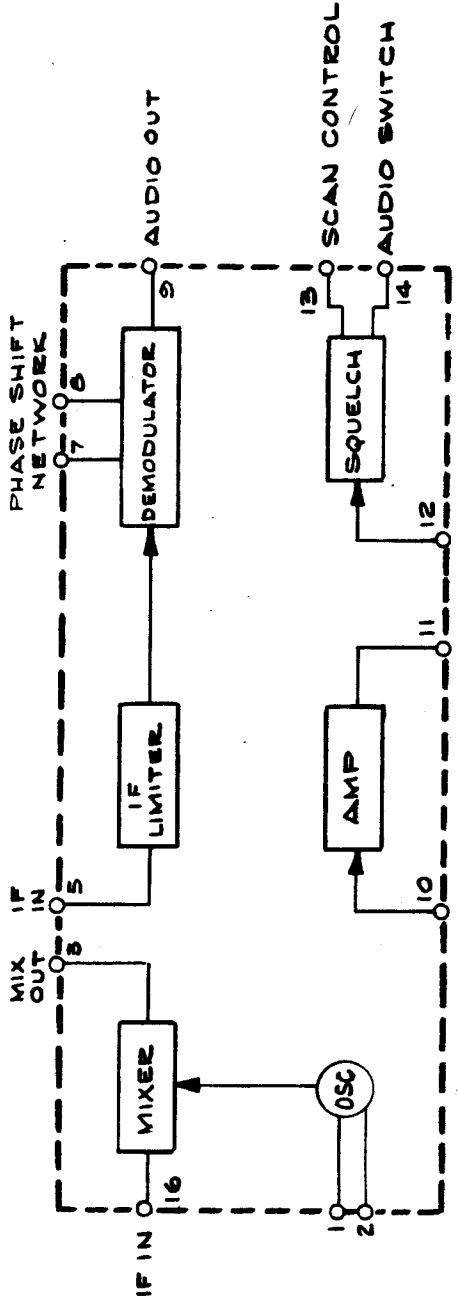

FIGURE 3
IC3 - NB53101

This information is confidential and proprietary to Masco Corporation of Indiana and shall not be divulged or used to the detriment of Masco Corporation of Indiana without written permission.

Ref. Models BC 250	
Approx. Scale NONE	DO NOT SCALE DWG.
Originator SAF/DVE	date 10/23/78
Dev. Eng. date	Mech. Eng. date
Prod. Eng. date	
Tolerances unless otherwise specified 2 Place dec. $\pm .010$ 3 Place dec. $\pm .005$ Fractions $\pm 1/64$ Angles $\pm 1/2^\circ$	
ELCITA COMPANY DIV. OF MASCO CORP. OF IND. CUMBERLAND IND. 48726	
Title BC250 (IC-3)	
Part No. XA 756	Rev.

DATE	CHANGE	REV

A B C D E F G 1 2 3 4 5 8

III. I.F.

The output of the LOW and HIGH band mixer is fed into the primary of T1, which steps the output down to a level that is comparable to the output level from the U BAND mixer. The signal, which is now at the 1st I.F. frequency (10.85MHz or 10.8MHz) goes through two crystal filters CF-1 and CF-2 to transformer T2. This filters out all frequencies except the I.F. and its modulation sidebands. From T2 the signal is coupled to Q16 which is just an untuned I.F. amplifier which increases the signal level that is fed into pin 16 of IC3.

Referring to Figure 3, the I.F. signal at Pin 16 of IC3 (NB53101) is mixed down to the second I.F. The second oscillator is within IC2 and controlled by the external crystal Y1. This 10.4MHz oscillator is internally mixed with the 10.85MHz I.F. input to produce the 450KHz second I.F. at Pin 3. The second I.F. is coupled through CF3 (Ceramic 450KHz filter) to the I.F. amplifier input at Pin 5. The I.F. is then limited and demodulated with the recovered audio output at Pin 9. T3, R63 and C65 provide the phase shift to balance the demodulator.

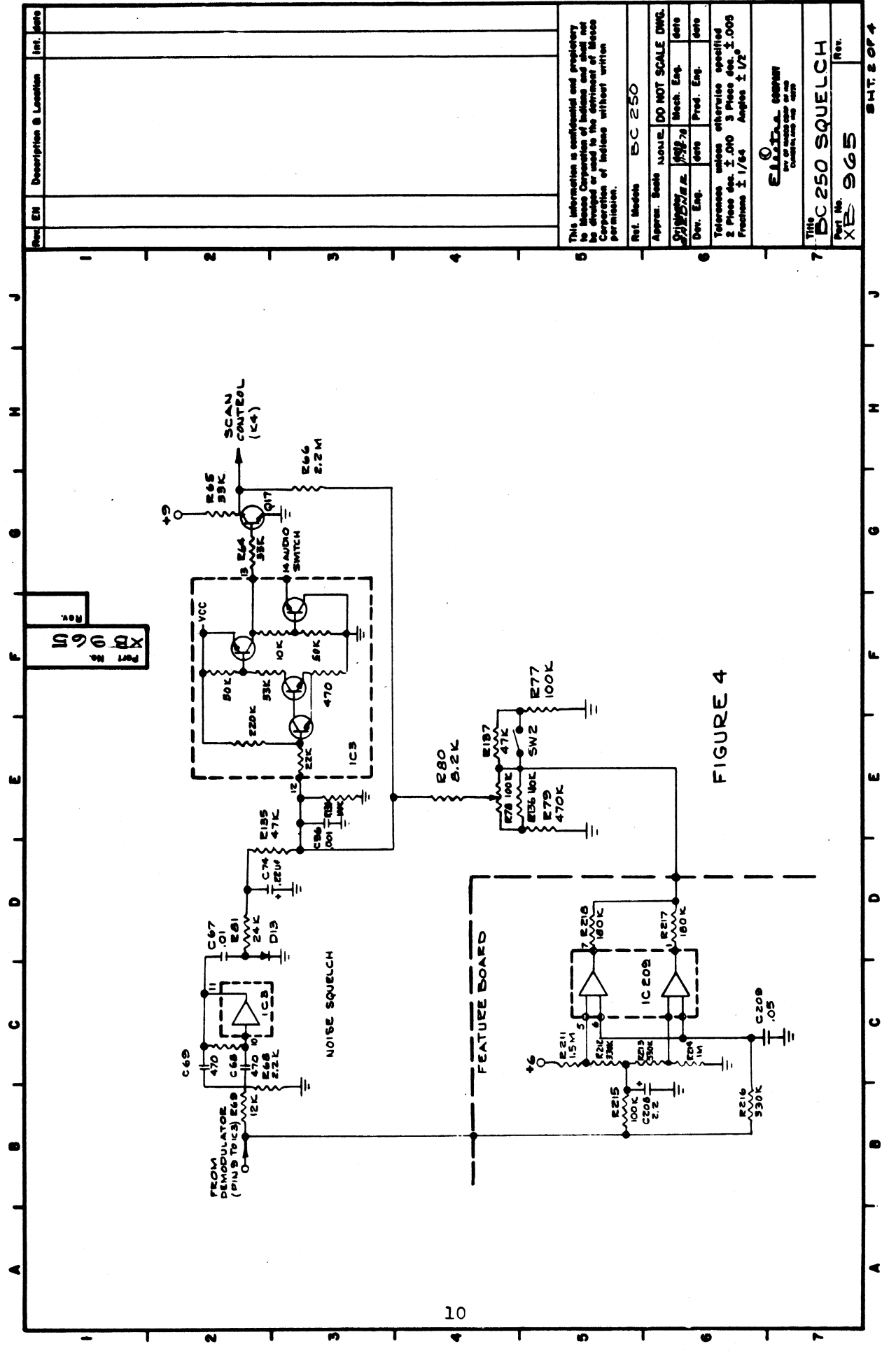

FIGURE 4

This information is confidential and proprietary to the Service Corporation of America and shall not be divulged or used in the development of a device or system without the written permission of the Service Corporation of America.

Ref. Model: BC 250

Approx. Scale: NONE. DO NOT SCALE DRAW.

Drawn: J. J. [unclear] Date: [unclear]

Dev. Eng. [unclear] Prod. Eng. [unclear]

Tolerance: unless otherwise specified
 2 Place dec. ± .010 3 Place dec. ± .005
 Fractions ± 1/64 Angles ± 1/2°

SAFARI COMPANY
 Div. of Service Corp. of Am.
 Distribution Ref. 5227

Title: BC 250 SQUELCH

Part No. XE 965 Rev. [unclear]

Sheet: 2 of 4

IV. a) AUDIO

The audio at Pin 9 of IC3 goes through the low-pass filter of R70 before coupled through C71 to the volume control R88. R82 - C75 and R83 - C76 form two additional pass circuits before the audio reaches the input of IC4 (NC66-301, TCA8305) which provides amplification to drive the speaker. The function of the external components is shown below:

R-84 sets the closed loop gain of the amplifier

C-82 & R-85 reduces saturation losses during positive half wave

C-79 sets upper cutoff frequency

C-81 couples audio to speaker and sets low cutoff frequency

C-80, R-86, & C-78 increases high frequency stability (prevents osc)

C-84 & C-83 filters ripple on power supply line

IV. b) SQUELCH

The noise squelch system uses an operational amplifier within IC3 as a bandpass amplifier. (Refer to Figure 4). The resonant frequency (8.5KHz), Q, and gain are determined by external components R67, R68, R69, C68, and C69. It is necessary to use this high frequency noise so normal audio frequencies do not activate the squelch system.

When no transmission is being received, the high frequency noise (8.5KHz) is amplified by IC3. The noise is then coupled through C67 and detected by D13 to produce a negative voltage which is filtered by R81 and C74. This negative voltage is then applied through R135 to pin 12 of IC3 which overcomes the positive bias provided by the squelch control R78 through R217 and R218 to pins 1 and 7 respectively of IC209 which are both normally high (+8.74 volts). With the voltage at pin 12 below the turn on level (due to the negative voltage from the detected noise) pin 13 voltage will go high to permit the receiver to scan and pin 14 will be low shutting off the audio at the volume control R31. When a signal is received, the resultant I.F. produces noise quieting through the system which reduces the 8.5KHz noise amplified by IC-3, thereby reducing the negative voltage level from the detected noise. This reduced negative level permits the positive bias of R78, R217, and R218 to reach the turn-on level at pin 12 of IC3 which forces pin 13 to go low to stop scanning and shuts off the pin 14 output to enable the audio to reach IC4 for amplification.

Q17 inverts the squelch output at pin 13 of IC3 to provide the scan control to the microprocessor on the Feature Board. The collector of Q17 is also fed back to the squelch input (pin 12) through R66 to provide squelch hysteresis.

FREQUENCY DETECTOR SQUELCH

The purpose of this circuit is to keep adjacent channel activity from unsquelching the radio. This would happen in conventional scanner radios in the presence of strong or interfering signals. This circuit will not let the radio unsquelch if the signal is more than 7KHz from received frequency.

The voltage comparator window is set up in IC209 (NB73402 - LM358N). The upper voltage limit is on pin 5, the lower voltage limit is on pin 3. These voltages are established by R211, R212, R213, and R214. If a voltage above the upper limit or below the lower limit appears on common pins 3 and 6, the output of pin 1 or 7 will go low. This reduces the voltage at pin 12 of IC3 forcing the receiver to continue scanning. The voltage is within the limits or "within the window" both outputs will be high. With both outputs high in normal operation, the squelch control R78 is used to set the bias for pin 12 of IC3. If these outputs are high and other squelch conditions acceptable, the radio will be unsquelched.

The discriminator output (IC3 pin 9) develops a d.c. voltage which is inversely proportional to frequency. The slope of the discriminator is approximately .18 volts/KHz (from the center frequency) and has a dc offset of 2.75v. dc. This voltage is filtered by R216 and C209 and serves as the window detector input.

IV. c) POWER SUPPLY

The voltage supply for the Bearcat 250 is developed by the full-wave rectifier circuit of T4, D18, and D19. This develops 16 volts, filtered by C98.

The 16 volts is regulated down to 6 volts (A) by R108, R109, and D17 which serves as supply voltage for IC3 and reference for Q21 and Q22 regulator circuits. The 6 volts (A) is applied to the inverting input of each half of IC5 (NB73-401 - MC1458P) so the output of each half will control the base of its associated transistor. The output of each transistor is divided down to 6 volts in the ratio required for +9 volts at the collector of Q22 (always ON) and +11 volts at the collector of Q21 (switched).

The +9 volt supply from Q22 provides voltage for IC6 and IC8 and is regulated down to +6 by R98 and D16 for voltage reference to IC2 (loop filter) and to maintain power for IC6, 7, and 9.

The unregulated 16 volts is connected to the Feature Board where it is regulated to +8.4 volts by R220, D210, Q206, and Q204 to supply power to all Feature Board Circuits except IC206 which uses a 6-volt supply derived from +8.4 volts by R219 and D208.

SECTION V - SYNTHESIZER

V. SYNTHESIZER

The Bearcat 250 synthesizer consists of a Voltage Controlled Oscillator (VCO) which is mixed down by 133MHz (H-U/T) and prescaled before division by a presettable counter controlled from memory. The output of this divider is compared to a reference frequency producing an error signal for a loop filter to compensate the VCO voltage to correct the frequency.

V.a) MIXER

The L or H/U/T VCO signal is coupled through C38 to an emitter - follower stage Q11 which serves as a buffer to drive the low-impedance input at pin 11 of the balanced mixer IC1 (NB85-401, TL442CN).

In H or U/T BANDS, the 133MHz oscillator signal from Q13 is coupled through R138 and C42 to the second mixer input at pin 5 of IC1. The (VCO-133MHz) difference frequency is present at the output pin 3 of IC1 where it is passed through the Low-Pass filter L19 and amplified by Q23 to drive the prescaler IC6.

On Low Band, the 133 oscillator does not operate since there is no Q13 base bias from D7 or D8. The second mixer input at pin 5 is also biased up through D6 to permit the mixer to pass the Low Band VCO frequency. The Low Band VCO frequency is then coupled to Q23 for buffering and amplification to drive IC6.

V. b) PRESCALER

The input at pin 2 of IC6 (NC57902) is divided by 15 or 16 with the output at pin 11. The division is by 15 when the control input pin 6 is HIGH and by 16 when LOW.

V. c) ÷ N

The prescaler output is connected to pin 7 of IC7 (NB25702) to clock the ÷ N and 12+A counters. Nine memory bits are used for presetting the ÷ N counter and four for the 12 + A counter to provide the proper division at the programmed frequency.

Initially the 12 + A counter output is HIGH and the ÷ N and 12 + A counter is clocked once for each 15 clocks at the prescaler. When 12 + A is reached, the output goes low to allow the prescaler to divide by 16 until the divide by N has reached its full count of $512 = 2^9$).

The ÷ N advances 12 + A times when the prescaler is dividing by 15 and the remainder $(512 - M - 12 + A)$ when the prescaler is dividing by 16. When the ÷ N has reached full count, it's output goes high to reset itself and the 12 + A counter to start over again. The total division by prescaler and ÷ N is therefore:

$$15 (12 + A) + 16 [512 - M - (12 + A)]$$

$$\text{Simplifying,} = 8180 - 16 M - A$$

V.d) PHASE COMPARATOR

The reference frequency for comparison with the $\div N$ output is derived from the 10.4MHz oscillator in IC3 controlled by Y2. The 10.4MHz signal is coupled to pin 16 of IC6 where it is divided by 4 for an output of 2.6MHz at pin 11 for an input at pin 5 of IC7. The 2.6MHz signal is then divided by 520 for LOW or HIGH VHF and by 624 for UHF controlled within IC7 by the U bandswitch information in memory. This provides a frequency of 5.0KHz on LOW and HIGH bands and 4.16667KHz ($4.16667 \times 3 = 12.5\text{KHz}$ channel spacing on U/T band) on UHF as a reference for comparing the $\div N$ output in the frequency phase comparator.

The phase comparator provides a tri-state output at pin 3 of IC7. This output will go low when the VCO and the $\div N$ output is low in frequency. When the VCO is high in frequency the output will go high. When both are in phase, the phase-comparator has a high impedance output.

V.e) LOOP FILTER

The phase comparator output is filtered and amplified by IC2. R95 and R96 establish a 3-volt bias on pin 5 of IC2 to match the bias on pin 6 provided by R91, 93, and R94. The correction pulses are applied through R89 and R90 and filtered by C85 to the inverting input of IC2.

(Loop Filter Continued)

If the VCO is running too low in frequency, negative correction pulses will go to the inverting input forcing the output DC voltage to go higher. Meanwhile, C88 in the feedback loop charges to oppose the input change and hold the output at this new level. In the same manner, if the VCO runs too high in frequency, positive correction pulses from the comparator will cause a decrease in the control voltage from IC2 forcing the VCO back down until the ÷N output is in phase with the reference to stop the correction pulses. When the VCO is on frequency and the comparator output is a high impedance, the charge on C88 will hold the control voltage keeping the VCO at that frequency. Since the width of the correction pulse is dependent on the degree of phase difference, the further the VCO is off frequency, the longer will be the pulse to correct it. D14 and D15 block noise less than 1.4 volts peak to peak coming from the phase comparator when its output is in the high impedance state.

V.f) BANDSWITCHING

The bandswitch data from memory is brought out on pins 2 (\bar{H}) and 20 (\bar{U}) of IC7. When \bar{H} is Low for High Band operation, base current for Q15 is supplied through D10 (7.5V Zener) and R51 to turn it on for 11 volts at the collector. Similarly, when \bar{U} is low, Q14 is turned on through D9 and R49 giving 11 volts at the collector for UHF operation.

(Bandswitching Continued)

When \bar{H} is HIGH (6 volts) for Low Band or UHF, D10 does not reach its Zener voltage prohibiting current through it, thereby shutting off Q15. Q14 is shut off in the same manner when U is HIGH for Low and High Band operation.

V.g) 433KHz/± 26 VOLTS

The 2.6MHz signal ($10.4\text{MHz} \div 4$) from IC6 (pin 14) is applied to the input pin 1 of IC9 (NB85-501, CD4520BC). IC9 is a dual binary UP counter with D20 and D21 used to reset the first counter when Q1 (pin 4) and Q2 (pin 5) are HIGH to provide a division by 6. This divide-by-6 output on pin 5 at 433.33KHz is coupled through R122 to the Control Board as the system clock.

The 433KHz signal at pin 5 is also connected to the input of the second counter at pin 9 of IC9. No reset is used on this section permitting a division by 16 to provide a 27KHz output at pin 14. The 27KHz output is coupled through R118 and C105 to the input pin 3 of IC8 (NB66801, LM386N) where it is amplified to drive T5. The stepped-up voltage at the secondary of T5 is detected by D22 and D23 to charge C113 to the positive peak voltage to develop a +26 volt source for the Tuning Voltage amplifier IC2. D24 and D25 detect the T5 secondary to charge C114 to the negative peak voltage for a -26 volt supply required for the memory IC202 on the Feature Board.

VI. FEATURE BOARD

IC207 (NA65802 - MM57129) and IC208 (NA65801 - MM5782) are a custom programmed microprocessor pair which accepts a decimal keyboard input and converts it to the appropriate binary code for synthesizer control. These also enter the data into memory and multiplex the information for an 11 digit seven segment display.

VI.a) KEYBOARD ENTRY AND DISPLAY

The decimal keyboard is used to control data inputs K1, K2, and K3 of the Microprocessor which decodes the timing of pulses from the digit scan outputs of IC206. The display data is multiplexed to supply source voltage to each required segment during the sequential strobing of the digit cathodes to display the information. IC208 provides a 4 bit binary code to IC206 (NB86101-DS8968N), a 12 digit decoder/driver which grounds the selected digit cathode. IC205 (NB86201 - DS8654N) is an eight section display driver to supply current for each segment through its associated 100ohm resistor in the R221 array.

Part No. XA 757
Rev.

FIGURE 5
HEX LATCH

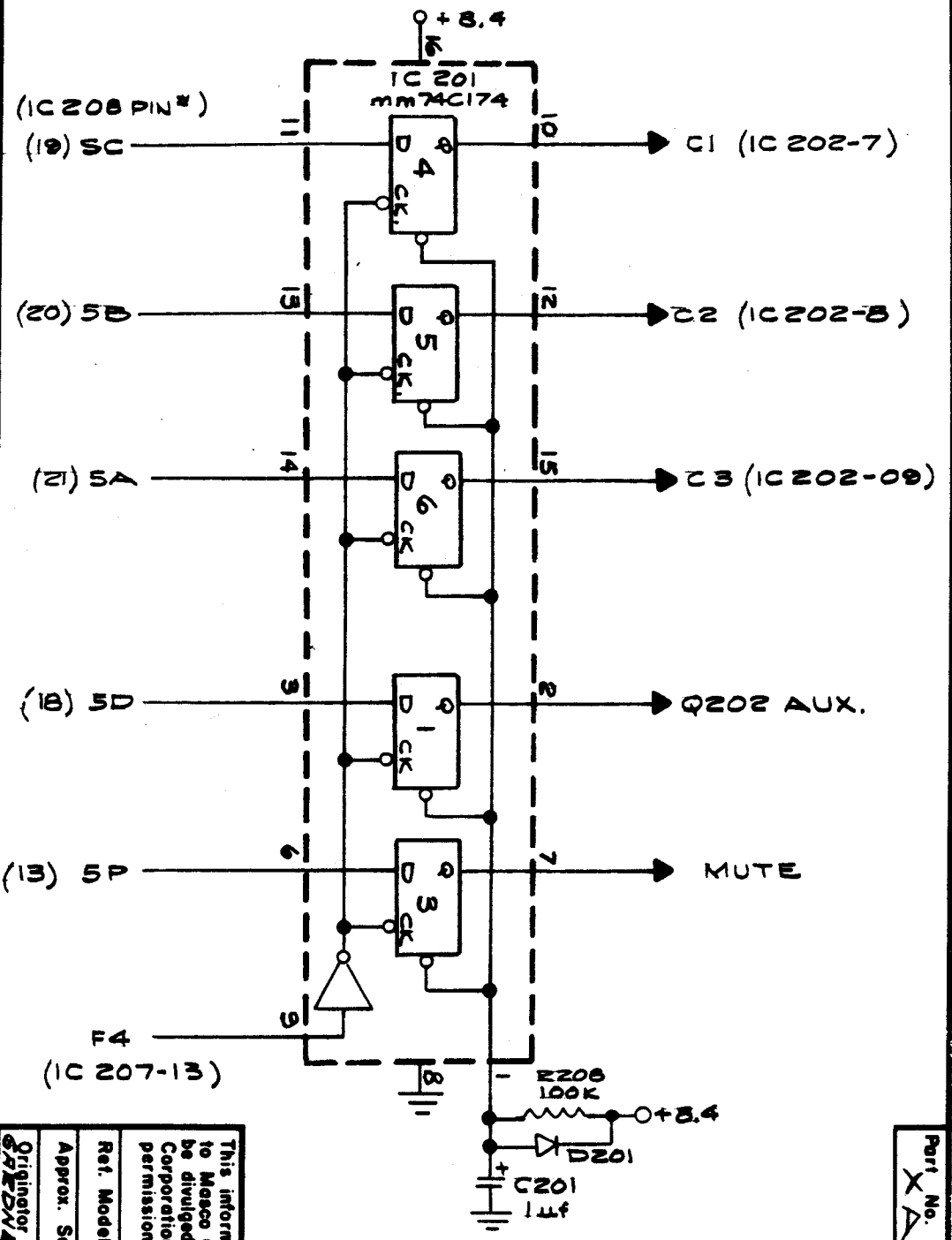

This information is confidential and proprietary to Masco Corporation of Indiana and shall not be divulged or used to the detriment of Masco Corporation of Indiana without written permission.

Ref. Models BC 250

Approx. Scale NONE DO NOT SCALE DWG.

Originator <i>SR/DM/BE</i>	date <i>1/28-78</i>	Mech. Eng.	date
Dev. Eng.	date	Prod. Eng.	date

Tolerances unless otherwise specified
2 Place dec. ± .010 3 Place dec. ± .005
Fractions ± 1/64 Angles ± 1/2°

ELASTAL COMPANY
DIV OF MASCO CORP OF IND
CAMBERLAND IND 46726

Title BC 250 HEX. LATCH
Part No. XA 757
Rev.

REV.	CHANGE	DATE

A B C D E F

G5HT 3084

VI.b) HEX LATCH

Referring to Figure 5, IC201 (NB85801 - MM74C174N) contains 6 D type flip-flops used as latches with a common clock line from F4 of the microprocessor (IC207). Five segment output lines (A,B,C,D, P) from IC208 are also used at F4 clock time to set the latches in the proper state for memory instruction and provide AUX. output and MUTE for squelching the audio during synthesizer data transfer time.

VI.c) MEMORY

IC202 (NB85901 - ER1400) is a 1400 bit Electrically Alterable Read Only Memory (EAROM) with a 100 word x 14 BIT organization. Two words (28 bits) are used for each of the 50 channels for frequency, bandswitching Delay, Lockout, and Count information. The device function for each input code from the IC201 latch is shown below:

<u>C1</u>	<u>C2</u>	<u>C3</u>	<u>FUNCTION</u>
0	0	0	Stand By
0	0	1	Not Used
0	1	0	Erase
0	1	1	Accept Address
1	0	0	Read
1	0	1	Shift Data Out
1	1	0	Write
1	1	1	Accept Data

(Memory continued)

The memory clock is driven from the F3 output of IC207. F2 accepts the serial data from memory and outputs data to the memory and synthesizer (IC7). F1 provides the clock to transfer data into the synthesizer. When the radio is turned OFF, F1 is pulled LOW through D203 to instruct the microprocessor to display time.

VI.d) SEARCH/TIME

IC204 (NB86601 - MM57126) is a 1024 bit serial RAM. In the SEARCH mode, data is transferred serially into IC204 using 16 bits per Search channel. This permits a 64 channel capacity. Data is also transferred serially back into IC208. IC207 contains a SYNC output for IC208 and IC204 which is the system clock (433KHz) divided by 4 (108.33KHz).

The 108KHz SYNC from IC207 is also sent to the clock input of IC203 (NB86001 - MM5369) which is a custom programmed divider. IC203 divides by 54,167 to provide a 2Hz output fed back to IC207. This signal is used by the microprocessor as reference for the real-time clock and the PRIORITY sample time.

BC-250 ALIGNMENT PROCEDURE

NO. DESCRIPTION	INPUT SIGNAL	ADJUSTMENT	NOTES
<p>1. L-Band - Tuning Voltage Calib.</p>	<p>None Radio programmed to 33.76MHz</p>	<p>Adjust L13 (violet) For 1.0V+ .05V volts at TP5. Adjust R72 for .40 volts at TP1.</p>	
<p>2. H-Band - Tuning Voltage calib.</p>	<p>None Radio programmed to 146.05</p>	<p>Adjust L14 (green) For 1.00V ±.05V at TP5.</p>	<p>It is important that the Sig. input level be adjusted to keep I.F. from limiting</p>
<p>3. I.F. Adjustment</p>	<p>Method 1 Apply a swept 10.85MHz signal to ant. input. It is desirable to sweep +25KHz at a 60Hz rate (or less). See notes for level. (Radio may be programmed to all L or H frequency).</p>	<p>Monitor output of TP2 with Det., Probe or the following circuit</p> <p>Scope should be set to .01 to .05V/Div. range. Adjust scope pattern T1 Maximum Amplitude T2 for min. ripple.</p>	<p>If sweep is at 60Hz rate. scope may be on line sync. otherwise, horizontal input must be attached to sweep signal.</p>
<p>4. Discriminator Adjustment</p>	<p>Method 2 Apply an L or H signal swept by a sawtooth waveform +25KHz Program radio to L or H signal generator frequency.</p> <p>No input signal and radio programmed 146.05.</p>	<p>Adjustment same as Method 1.</p> <p>Adjust T3 to give 2.8V ± .1V at pin 9 of IC3</p>	<p>Conventional disc. should not be used on this radio. The window det. circuit relies on proper adj. of this coil.</p>

NO. DESCRIPTION	INPUT SIGNAL	ADJUSTMENT	NOTES
5. L-Band frequency alignment	<p>Preferred <u>method 1</u> -- none</p> <p><u>Method 2</u> Apply a 33-35MHz L-Band signal @ 1mv. The accuracy of the signal generator or counter on the signal generator must be .0003% (3ppm) of <u>+150Hz</u>.</p>	<p>Measure freq. *at pin 14 of IC6 - adjust C58 for 2.6MHz exactly. *Counter accuracy .003% or better (<u>+80Hz</u>)</p>	<p>Couple TP4 thru a .005uf cap. to counter.</p>
6. H & U/T frequency Alignment	<p><u>Method 1</u> Apply any U/T-Band signal (450-512). Accuracy of generator or counter on generator must be .0004% (4ppm) or <u>+200Hz</u>. <u>Program radio to U/T</u> signal frequency.</p> <p><u>Method 2</u> No input signal. Radio on H or U/T channel using a pickup loop (9-10) turns 18-22ga. wire on 3/4" dia. attached to coax monitor on a frequency counter 133MHz. Accuracy of counter must be .0002% (2ppm) or <u>+330Hz</u>.</p>	<p>Measure IF with counter at TP4. Adjust C58 for 450KHz <u>+50Hz</u>.</p> <p>Measure I.F. with counter at TP4 - adjust L16 for 450KHz <u>+500Hz</u>.</p> <p>Adjust L16 for 133MHz exactly.--pick-up loop placed near Y1.</p>	<p>Adjust of L16 aligns H & U/T-Band.</p> <p>Some detuning of 133 osc. may occur if loop is too tightly coupled. Use minimum coupling to get an accurate counter reading.</p>

NO. DESCRIPTION	INPUT SIGNAL	ADJUSTMENT	NOTES
7. U/T Sensitivity alignment	453.25MHz @ 2uV to antenna input. Program radio to 453.25 MHz.	Adjust C2, C5, and C17 for best quieting at audio output (tuning voltage at TP5 will be approximately 5.8V.)	It may be necessary to reduce sig. level below 2uV to the point where the effect of adjustment can be measured.
8. Quieting adjustment	453.25MHz @ 1mV to antenna Input.	Adjust R91 for best quieting at audio output.	
9. H-Band sensitivity Alignment	Apply a 146.05 signal @ 1uV to antenna input. Program radio to 146.05.	Adjust L9 and L11 (pink) for best quieting at audio output.	It may be necessary to reduce signal level and re-adjust L9 and L11.
10. L-Band Sensitivity Alignment.	Apply 40-42MHz signal @ 1uV to antenna input. Program radio to test frequency.	Adjust L10 and L12 (green) for best quieting at audio output.	It may be necessary to reduce signal level and re-adjust L10 and L12.

BC-250 SYMPTOM & CURE AIDS

SYMPTOM

COMPONENT

- 1) No or weak rec. on L band
No Frequencies, Q4, Q5, band switching
- 2) No or weak rec. on H band
No frequencies, Q4, Q5, band switching
- 3) No or weak rec. on U/T band
No frequencies, Q1, Q2, Q3, C2, 5, 17 shorted, band switching
- 4) No or weak I.F.
IC3, CF1, CF2, CF3, T1, T2
- 5) No frequency L band
IC6, IC7, Q6 & 7, band switching, Q11, Q23
- 6) No frequency H & U band
IC6, IC7, Q8, band switching, Q13, Q11, Q23, Y1
- 7) No squelch or won't unquielch
IC209, IC3, D13, Q17, R78
- 8) No audio
IC4, Open J2, No I.F., Q20 (shorted), IC3
- 9) Power supply
T4, IC5, Q21, Q22, D17, Q204, D210, D16, R98
- 10) Won't program
No -26V, IC202, IC207, IC208, Q205, Q201, IC201
- 11) Won't hold program
Low -26 volts, IC202, Q201, Q205
- 12) Missing Segments
IC205, R221, IC208, IC207
- 13) Missing digit
IC206, IC208, IC207
- 14) No display or dot
Y2, Power supply, IC6, IC9, IC207, IC208, IC203, IC204, Q203, IC3, D208

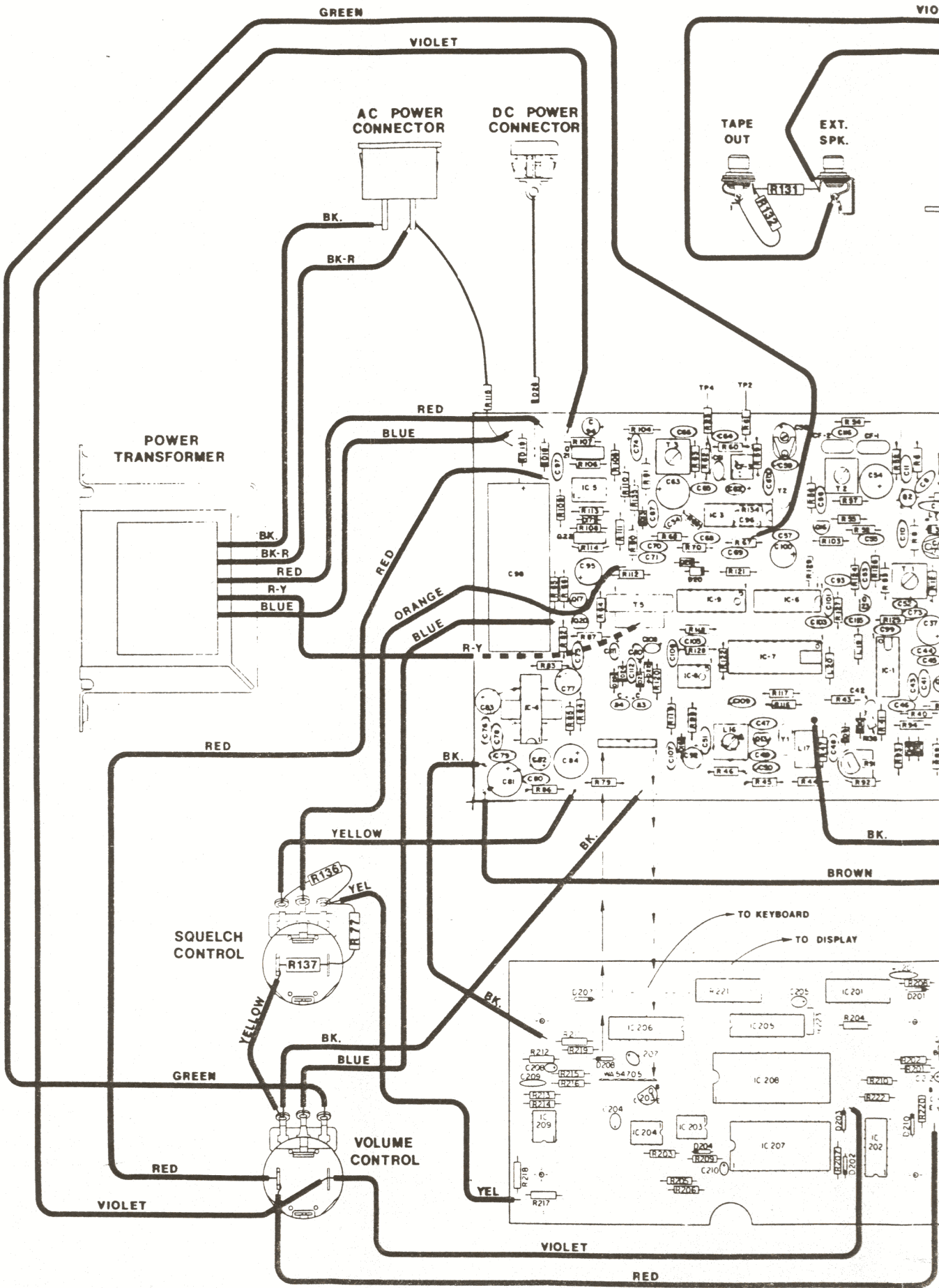

GREEN

VIO

VIOLET

AC POWER CONNECTOR

DC POWER CONNECTOR

TAPE OUT

EXT. SPK.

BK.

BK-R

RED

BLUE

POWER TRANSFORMER

BK.

BK-R

RED

R-Y

BLUE

RED

ORANGE

BLUE

R-Y

RED

BK.

YELLOW

SQUELCH CONTROL

R135

YEL

R137

R77

YELLOW

BK.

GREEN

BLUE

VOLUME CONTROL

RED

VIOLET

YEL

VIOLET

RED

BROWN

TO KEYBOARD

TO DISPLAY

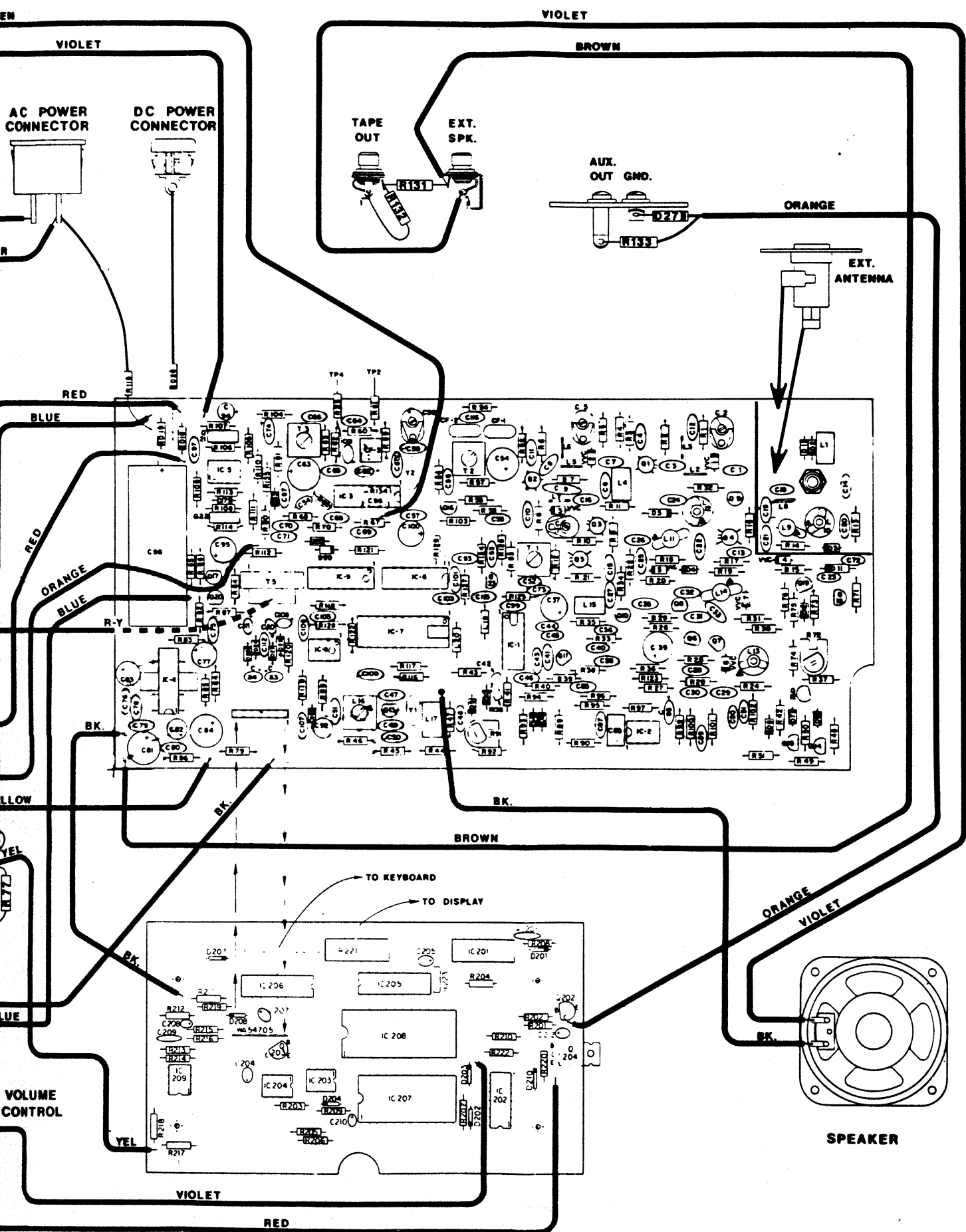

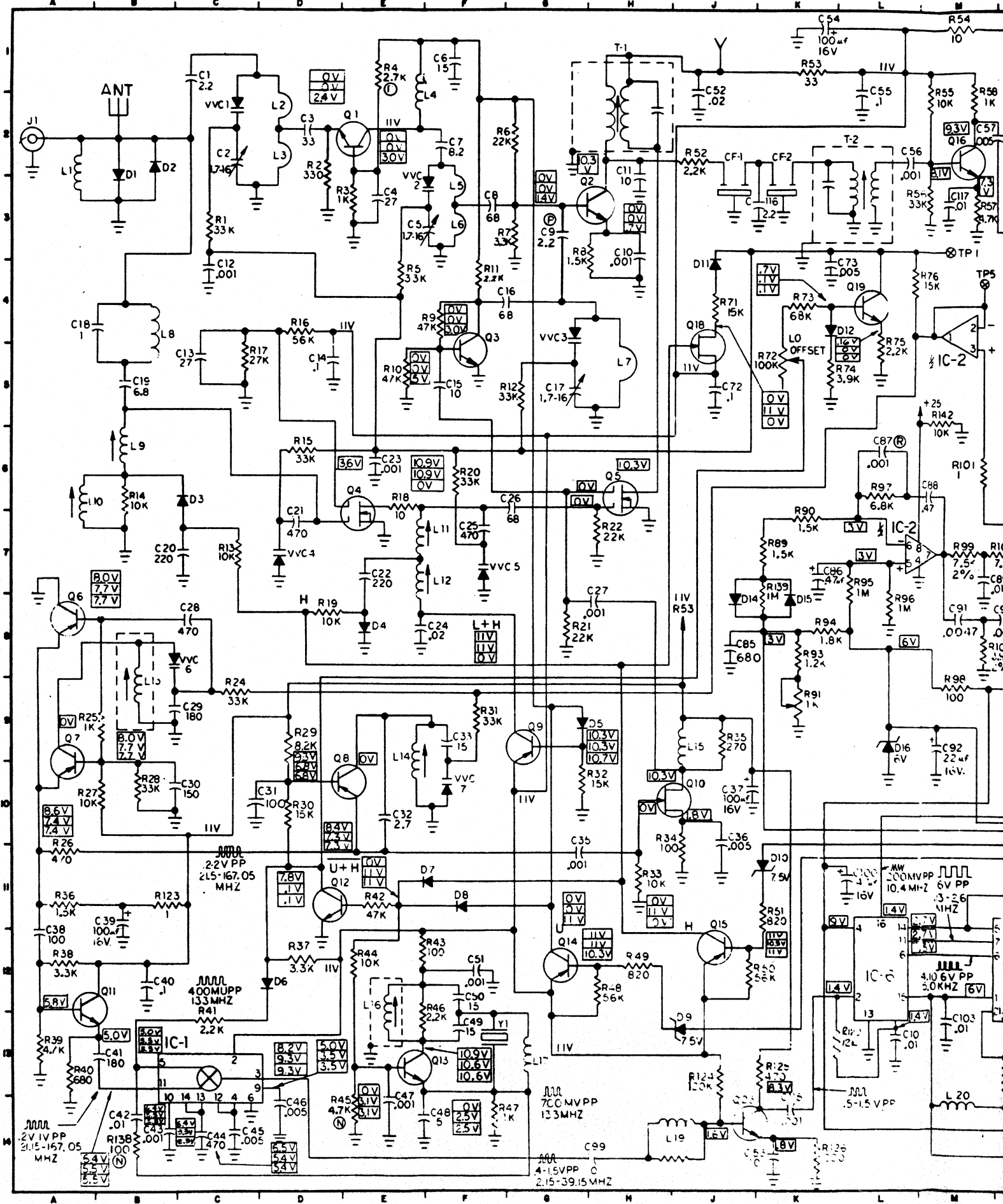

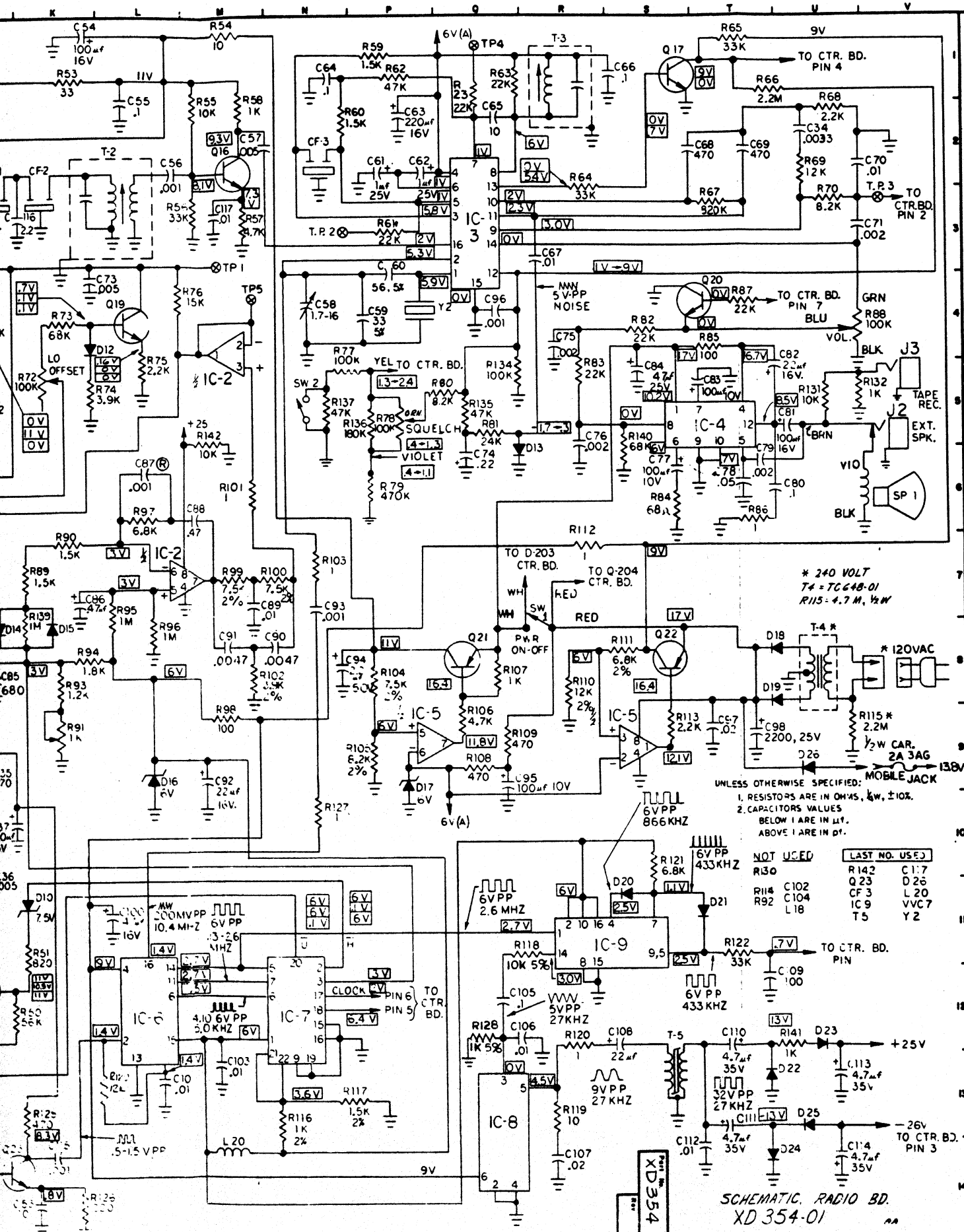

* 240 VOLT
 T4 = TC648-01
 R115 = 4.7 M, 1/2 W

UNLESS OTHERWISE SPECIFIED:
 1. RESISTORS ARE IN OHMS, K Ω , W, \pm 10%
 2. CAPACITORS VALUES
 BELOW ARE IN pF.
 ABOVE ARE IN μ F.

NOT USED		LAST NO. USED	
R130	C102	R142	C1:7
R114	C104	Q23	D26
R92	L18	CF3	L20
		IC9	VVC7
		T5	Y2

SCHEMATIC, RADIO BD.
 XD354-01

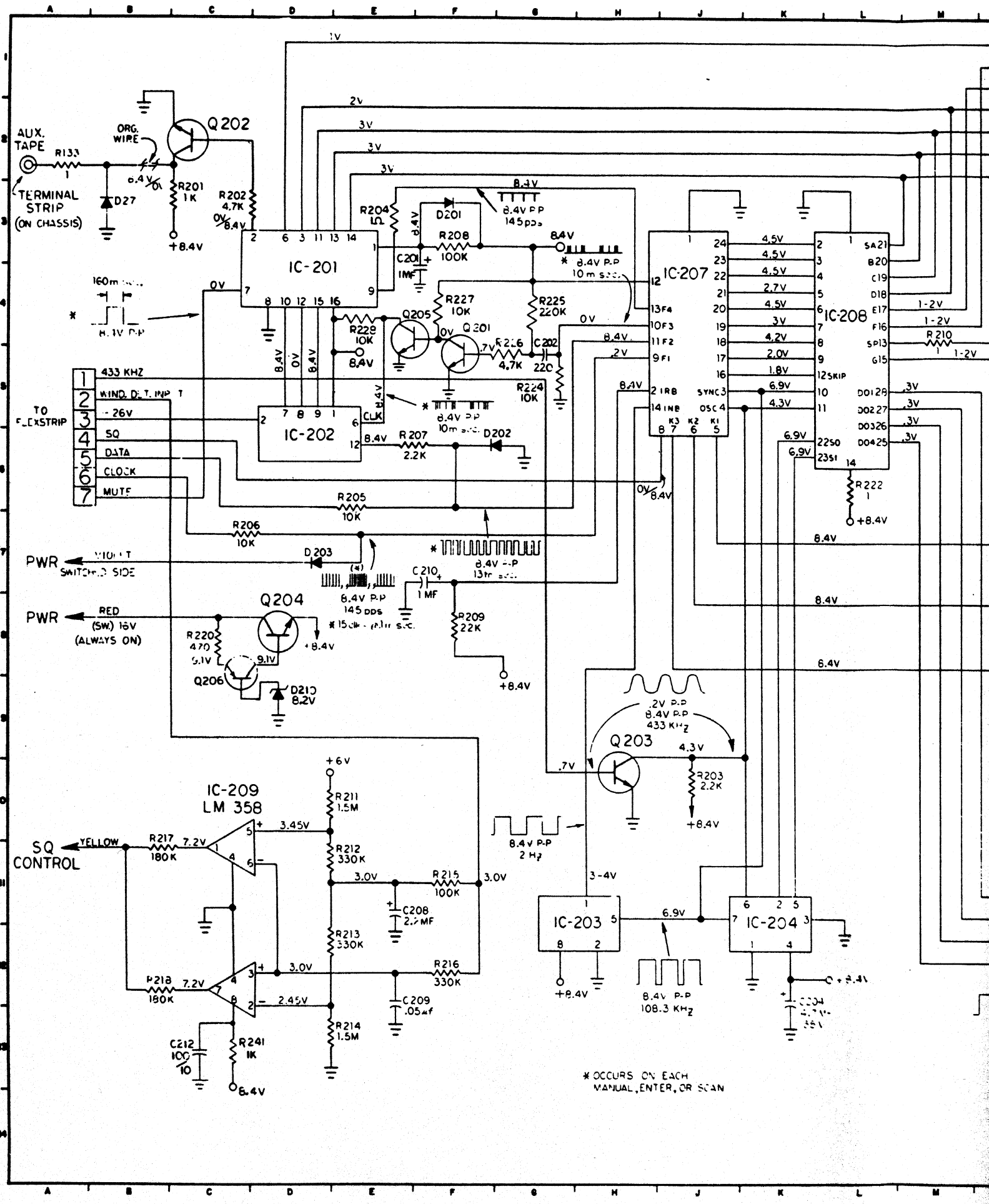

AUX. TAPE
 R133
 TERMINAL STRIP
 (ON CHASSIS)

Q202
 R201 1K
 R202 4.7K
 +8.4V

IC-201

TO
 F. EXSTRIP

1	433 KHZ
2	WIND. D.T. IMP T
3	-26V
4	SQ
5	DATA
6	CLOCK
7	MUTE

IC-202

IC-207

IC-208

IC-209
 LM 358

IC-203

IC-204

* OCCURS ON EACH
 MANUAL, ENTER, OR SCAN

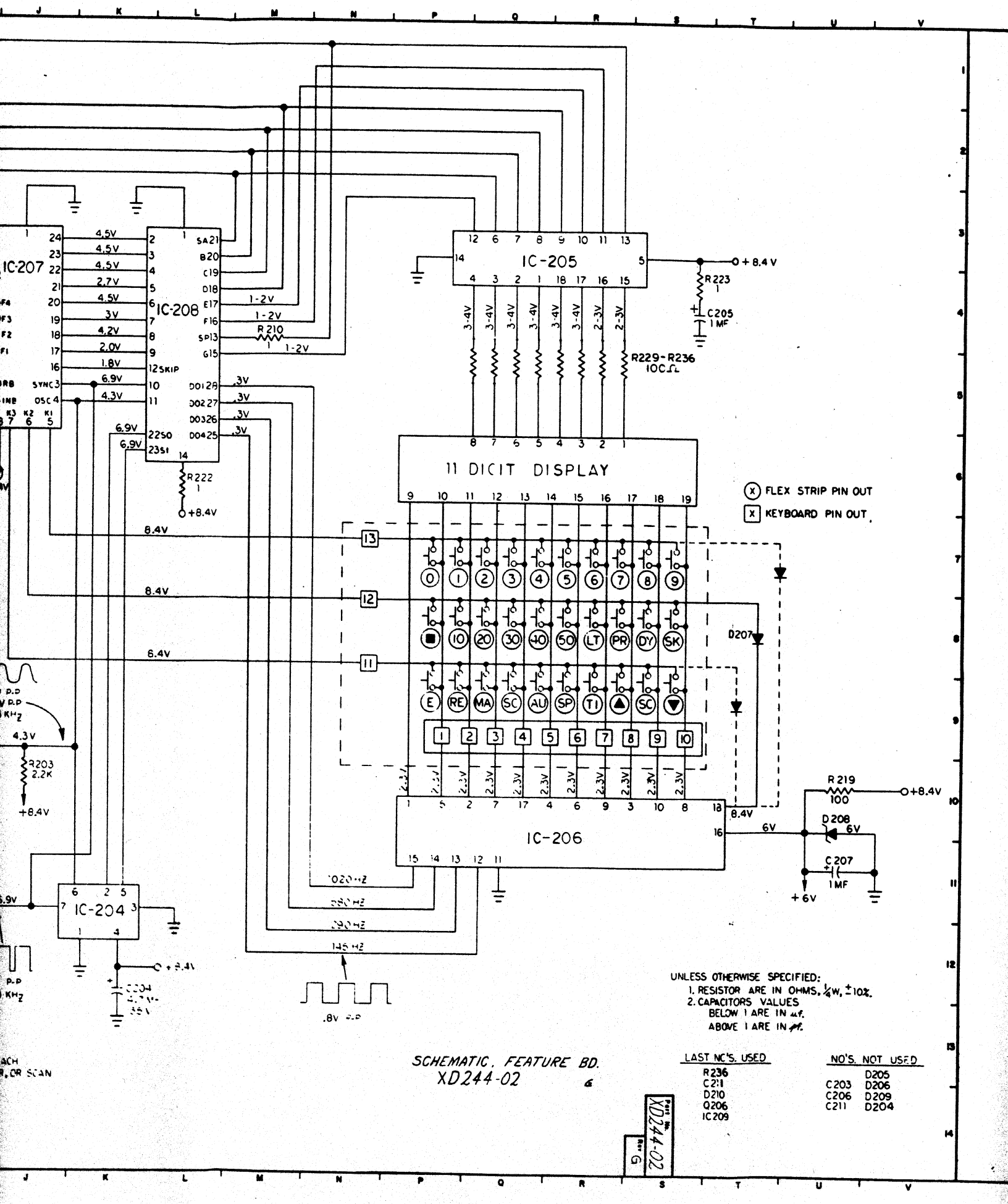

PARTS LIST

BC-250 & BC-250F (**)

<u>PLACEMENT</u>	<u>DESCRIPTION</u>	<u>ELECTRA NUMBE</u>
	SP575 Double Sided Tape ¼" X 2.00 Long	A102-000
Beneath junction of C202,R225 & R226	#4032 Tape	A106-000
Req. 1 Inch	1/8 In. Sleeving Alpha Fit Heat Shrink	A130-000
	Keyboard	BC62-301
	PC Board, Radio	BD22-601
	PC Board, Feature	BD22-702
C18	1 PF NPO+/- .25 NPO 100V Cer	C103-010
C2,C5,C17,C58	1.7-16PF Plastic Var Cap	CB74-301
C9	2.2 PF NPO 10% Tubular Capacitor	C914-000
C1, C116	2.2 PF +/- .25 NPO Cer 100V	C103-022
C32	2.7 PF +/- .25 NPO Cer 100V	C103-027
C48	5 PF +/- .25 NPO Cer	C103-050
C19	6.8 PF 10% NPO Cer 100V	C102-068
C7	8.2 PF 5% NPO Cap	C101-082
C11,C15,C53, C65,C99	10 PF Cap 5% NPO CD	C101-100
C6,C33,C49,C50	15 PF 5% NPO CD Cap PIPI	C101-150
C4,C13	27 PF 10% NPO 100V Cer	C102-270
C59	33 PF NPO +/-5% Cer PTPI	C101-330
C3	33 PF 10% NPO Cer Cap	C102-330
C60	56 PF NPO +/- 5% PTPI	C101-560
C8,C16,C26	68 PF 10% N1500 Cer Disc	C122-680
C31,C38	100 PF Z5F 10% PTPI Cer Disc	C142-101

** BC-250F (240 Volt)

<u>PLACEMENT</u>	<u>DESCRIPTION</u>	<u>ELECTRA NUMBER</u>
C109	100 PF 20% Z5F Cap PTPI C.D.	C143-101
C30	150 PF 20% Y5F	C133-151
C29, C41	180 PF 10% Z5F PTPI Cer. D.	C142-181
C20, C22, C202	220 PF 20% Z5F Cap PTPI CD	C143-221
C21, C25, C28, C44, C68, C69	470 PF Z5F 10% PTPI Cer Disc	C142-471
C85	680 PF Z5F 10% PTPI Cer Disc	C142-681
C90, C91	.0047 MF 5% 100V Mylar	C506-472
C34	.0033 MF 10% Z5P 100V Mylar	C503-332
C87	.001 MF Mylar Cap 10% 100V Epoxy / Coat	C503-102
C10, C12, C23, C27, C35, C43, C47, C51, C56, C93, C96,C115	.001 MF Z5U GMV 500V Cer Cap PTPI	C345-102
C71, C75, C76, C79	.002 MF 20% Z5U 500 CD A280	C305-202
C36, C45, C46, C57, C73	.005 MF 20% Z5U 100V Cer	C304-502
C67, C89	.01 MF 5% 100V Mylar	C506-103
C42, C70, C101,C103, C106, C112, C117	.01 MF 20% Z5U 100V Cer	C304-103
C24, C52, C97, C107	.02 MF 20% Z5U 50V Cer	C303-203
C78, C209	.05MF 20% 12V Z5U Cer PIPI	C301-503
C74	.22 MF 20% 10V Tant	C602-224
C88	.47 MF 10% Z5P 100V Poly	C503-474
C86	.47 MF 20% 35V Tant	C606-474
C14, C40, C55, C64, C66, C72, C80,C105	.1 MF 20% 12V Z5U PTPI	C301-104
C61, C62, C201, C205, C207, C210	1 MF 20% 25V Min. Tant	C605-105

<u>PLACEMENT</u>	<u>DESCRIPTION</u>	<u>ELECTRA NUMBER</u>
C208	2.2 MF 20% 25V Tant	C605-225
C94	2.2MF +80/-20 TW 50V Elect	C756-225
C204	4.7 MF 20% 16V Tant	C603-475
C110, C11, C113, C114	4.7 MF 35V Tant	C606-475
C108	22 MF 20% 10V Tant	C602-226
C82, C92	22 MF +100/-10 16V TW Elect	C733-226
C100	47 MF Cap +100/-10 16V TW	C733-476
C84	47 MF 25V Elect TW	C754-476
C77, C83, C95	100 MF +80/20% 10V Elect TW	C751-107
C37, C39, C54, C81	100 MF Elect 16V Stand Up +80/-20	C753-107
C63	220 MF -10/+100 16V Elect TW	C733-227
C98	2200 MF 25V Elect TT	C707-228
VVC6, VVC7	Siemens #BB109 Tuning Diode Matched S	DA22-501
D5, D11	Hitachi #IN34A	DB68-401
D18, D19, D26, D27	Gen. Inst. #IN4002 or IN4002 G.P.	DB70-301
VVC4, VVC5	Siemens #BB209 Tuning Diode Matched S	DB70-601
VVC1, VVC2, VVC3	Siemens #BB105A Tuning Diode Matched S	DB70-701
D9, D10	N.P.C. #IN755A 7.5V 5% 400MW Zener	DB70-803
D16, D17, D208	APD IN5233B 6V 5% Zener	DB72-302
D3, D4	Motorola #MPN 3401	DB73-101
D1, D2, D6, D7, D8, D12, D13, D14, D15, D20, D21, D22, D23, D24, D25, D201, D202, D203, D207	Hitachi IN4148	DB73-602
D210	8.2V 5% 500MW Zener Diode	DB96-101

<u>PLACEMENT</u>	<u>DESCRIPTION</u>	<u>ELECTRA NUMBE</u>
	9/32 Odx. 133 IDX .025 Thk. Washer	FA36-801
Mobile Mounting Bracket	Nylon Shoulder Washer	FA57-801
Serial Tag	Rivet, Steel 1/8 x.155 AVDEL	FB80-901
Use with HB89001 Foot	Rivet 1/8 X .235	FB80-902
Ant. Connector to Chassis	Rivet Stl.1/8 X 3/16 Semi-Tubular Z O	F102-000
Terminal Strip to Chassis	Rivet Stl.1/8 X7/32 Semi-Tubular Z O	F108-000
Mobile Mounting Bracket	¼ ID X9/16 OD Flat Washer Cad	F202-000
Antenna Bushing	#10 Internal Washer Cad	F205-000
Display Holder	Spring Washer .283 OD	F210-000
Antenna Bushing	10/32 X 5/16 Hex Nut Cad	F306-000
	#8 Internal Tooth Lockwasher Zinc OR	F321-000
Under JB598 Jacks	Int. TTh. Lck. Wshr. .256/.267 ID	F322-000
Display Holder	Spring Clip .125 ID	F401-000
	Antenna Insulator	HA21-501
	Antenna Ground Strap	HA26-402
	Plug Button	HA27-101
	Can Coil	HA46-301
	Insulator AC	HA62-101
	Logo Inlay	HA82-901
	Bracket Mobile Mounting	HB23-402
	Knob	HB46-403
	Inlay Volume	HB46-504
	Keytop Cushion	HB82-401
	Keytop, Orange	HB82-501

PLACEMENTDESCRIPTIONELECTRA NUMBER

Keytop, Rust	HB82-502
Keytop, Beige	HB82-503
Keytop, Yellow Ochre	HB82-504
Control Inlay	HB85-201
Foot	HB89-001
Snap Bushing	HB89-903
Antenna Bushing	HB91-601
Display Holder	HC51-701
Metal Serial Tag	HC60-417
Keyboard Inlay	HC62-401
Mounting Bracket	HC66-401
Shield, RF	HC66-901
Cover, AC 250	HC67-501
Front Panel	HD11-302
Wraparound	HD11-402
Chassis Assembly Wrap-Around	HD22-301
Antenna Plug	JA12-701
Terminal Bushing Heyco DC251-1	JA22-202
Terminal T101-S	JA22-203
Antenna Connector	JA36-201
I.C. Socket - 14 Pin	JA80-101
Jack - Earphone 3.5MM Dia.	JB60-501
24 Pin IC Sooket With Lead in Cover	JB88-702
IC Socket - Burndy 28 Pin	JB91-201
A.C. Interlock Receptacle	JB95-201
Connector, Top Entry	JC65-701

J2, J3

<u>PLACEMENT</u>	<u>DESCRIPTION</u>	<u>ELECTRA NUMBER</u>
L15	Choke White	LA21-801
L4	Choke Blue	LA21-804
L17	Coil Red	LA21-806
L7	Coil	LA50-801
L2, L3, L5	Coil	LA50-802
L6	UHF Coil	LA50-803
L8	Choke	LA50-901
	Choke 2.5 UH 10%	LA54-501
	Coil L Osc 17 $\frac{1}{2}$ T	LB42-903
L14	Coil H Osc. 3 $\frac{1}{2}$ T	LB43-001
L9, L11	Coil	LB50-102
L10, L12	Coil	LB51-102
L3	Coil	LB53-303
L16	Coil Osc Green	LB91-301
	Antenna	MA13-802
	2 Amp - 3 Ag Fuse	MA37-602
	Fuse Holder	MA62-201
Power Cord	Terminal Fully Insulated	MA64-001
Ground Cord Assy.	Terminal	MA64-901
DC Power Cord	Contact Fuse	MA65-201
DC Power Cord Assy.	Spring	MA90-201
	Speaker	MB33-202
	Terminal Strip	MB88-301
	Display-11 Digit Numeric, T.I.	MC62-201
	A.C. Power Cord	MC64-703

<u>PLACEMENT</u>	<u>DESCRIPTION</u>	<u>ELECTRA NUMBER</u>
**	A.C. Power Cord	MC72-003**
IC208	Cops MM5782 IC	NC73-901
IC207	Cops MM57129 IC	NA65-803
IC7	Amer Micro Systems #B257-2 Custom	NB25-702
IC3	IC IF 16 Pin SC8780P B1841	NB53-101
IC8	National #LM386N	NB66-801
IC5	T.I. #MC1458P	NB73-401
IC2, IC209	National #LM358N	NB73-402
IC1	TL442CN Balanced Mixer	NB85-401
IC9	National CD4520BC IC	NB85-501
IC201	National MM74C174N IC	NB85-801
IC202	G.I. ER1400 I.C.	NB85-901
IC203	National MM5369 ETD/N	NB86-001
IC206	National DS8968N Custom IC	NB86-101
IC205	National DS8654N IC	NB86-201
IC204	Cops Memory-National MM 57126	NB86-601
IC6	Exar #NC57902 Custom	NC57-902
IC4	SGS/ATES TCA 830S Audio Amplifier	NC66-301
Q4, Q5	T.I. #C2T204 or T.I. 2N5179	QA15-701
Q203	Motorola MPS H-17 EL#617	QB72-501
Q1, Q2, Q3	National #2N5179	QB72-601
Q22	T.I. # Tip 30	QB74-401
Q204	T.I. # Tip 29	QB74-501
Q13	Hitachi #2SC1907	QB75-202
Q11, Q16, Q23	Fairchild #2N3563	QB75-902
Q18	Motorola #SPF792	QB76-101

** BC-250F (240 Volt)

<u>PLACEMENT</u>	<u>DESCRIPTION</u>	<u>ELECTRA NUMBER</u>
Q21	National #92PE77A	QB76-402
Q2	National 92PU45A	QB91-501
Q201, Q205	Mtrola #MPS3393 SPS6557 EL403Beta 50	QC58-101
Q12, Q17, Q19, Q20	National #MPS3393 Process 07	QC58-102
Q6, Q7, Q8, Q206	Mtrola #MPS3640 SPS758 EL271	QC59-202
Q9, Q14, Q15	Motorola #2N4126	QC59-601
Q10	2N5486 J Fet Transistor Motorola	QC66-502
R133	1 ohm $\frac{1}{2}$ W 5% Carb Film LL	R102-010
R86, R101, R103, R112, R120, R121, R127, R204, R210, R222, R223	1 Ohm $\frac{1}{2}$ 10%	R100-010
R18, R54, R119	10 Ohm $\frac{1}{2}$ W Gen Res	R100-100
R53	33 Ohm $\frac{1}{2}$ W Gen Res	R100-330
R84	68 Ohm $\frac{1}{2}$ W Gen Res	R100-680
R220, R230, R231, R232, R234, R235, R236, R34, R43, R85, R98, R138, R219	100 Ohm $\frac{1}{2}$ W Gen Res	R100-101
R126	220 Ohm $\frac{1}{2}$ W Gen Res	R100-221
R35	270 Ohm $\frac{1}{2}$ W Gen Res	R100-271
R2	330 Ohm $\frac{1}{2}$ W Gen Res	R100-331
R26, R108, R109, R125, R220	470 Ohm $\frac{1}{2}$ W Gen Res	R100-471
R40	680 OHM $\frac{1}{2}$ W Gen Res	R100-681
R49, R51	820 Ohm $\frac{1}{2}$ W Gen Res	R100-821
R91	1K Res Trimpot Piher PT 10V	RB71-501
R3, R25, R47, R58, R107, R141, R201	1K $\frac{1}{2}$ W Gen Res	R100-102
R128	1K $\frac{1}{2}$ W 5%	R101-102

<u>PLACEMENT</u>	<u>DESCRIPTION</u>	<u>ELECTRA NUMBER</u>
R132	1K ½W Gen Res LL	R150-102
R116	1K ½W 2% Carbon Film C/F Resistor	R303-102
R8, R36, R59, R60, R89, R90	1.5K ½W Gen Res	R100-152
R117	1.5K ½W 2% Carbon Film C/F Resistor	R303-152
R94	1.8K ½W Gen Resistor	R100-182
R41, R46, R52, R68, R75, R113, R203, R207, R11	2.2K ½W Gen Res	R100-222
R4	2.7K ½W Gen Res	R100-272
R7, R37, R38	3.3K ½W Gen Res	R100-332
R74	3.9K ½W Gen Res	R100-392
R102	3.9K ½W 2% Carbon Film C/F Resistor	R303-392
R39, R45, R57, R106, R202, R226	4.7K ½W Gen Res	R100-472
R97, R121	6.8K ½W Gen Res	R100-682
R111	6.8K 2% ½W Carbon Film C/F Resistor	R303-682
R99, R100, R104	7.5K 2% ½W Carbon Film C/F Resistor	R303-752
R29, R70, R80	8.2K ½W Gen Res	R100-822
R105	8.2K ½W 2% Carbon Film C/F Resistor	R303-822
R13, R14, R19, R27, R33, R44, R55, R131, R205, R206, R224, R227, R228, R142	10K ½W Gen Res	R100-103
R118	10K ½W 5%	R101-103
R93	12K ½W Gen Resistor	R100-122
R69, R129	12K ½W Gen Resistor	R100-123
R110	12K ½W Carbon Film C/F Resistor 2%	R303-123

<u>PLACEMENT</u>	<u>DESCRIPTION</u>	<u>ELECTRA NUMBER</u>
R30, R32, R71, R76	15K $\frac{1}{2}$ W Gen Res	R100-153
R6, R21, R22, R23, R61, R63, R82, R83, R87, R209	22K $\frac{1}{2}$ W Gen Res	R100-223
R81	24K Res 5% $\frac{1}{2}$ W	R101-243
R17	27K $\frac{1}{2}$ W Gen Res	R100-273
R1, R5, R12, R15, R20, R24, R28, R31, R56, R64, R65, R122	33K $\frac{1}{2}$ W Gen Res	R100-333
R9, R10, R42, R62, R135	47K $\frac{1}{2}$ W Gen Res	R100-473
R137	47K $\frac{1}{2}$ W Gen Res LL	R150-473
R16, R48, R50	56K $\frac{1}{2}$ W Gen Res	R100-563
R73, R140	68K $\frac{1}{2}$ W Gen Res	R100-683
R72	100K Res Trimpot Piher PT 10V	RB71-502
R88	100K Pot-Switch	RC53-602
R78	100K Pot-Switch	RC53-603
R134, R208, R215	100K $\frac{1}{2}$ W Gen Res	R100-104
R77	100K $\frac{1}{2}$ W Gen Res LL	R150-104
R124	120K Ohms $\frac{1}{2}$ W 10%	R100-124
R217, R218	180K $\frac{1}{2}$ W Gen Res	R100-184
R136	180K $\frac{1}{2}$ W Gen Res LL	R150-184
R225	220K $\frac{1}{2}$ W Gen Res	R100-224
R212, R213, R216	330K $\frac{1}{2}$ W Gen Res	R100-334
R79	470K $\frac{1}{2}$ W Gen Res	R100-474
R67	820K Res 10% $\frac{1}{2}$ W	R100-824
R95, R96, R139	1M $\frac{1}{2}$ W Gen Res	R100-105
R211, R214	1.5M $\frac{1}{2}$ W Gen Res	R100-155
R66	2.2M $\frac{1}{2}$ W Gen Res	R100-225

<u>PLACEMENT</u>	<u>DESCRIPTION</u>	<u>ELECTRA NUMBER</u>
R115	2.2M ½W 10% Carbon Comp Res LL	R214-225
** R115	4.7M ½W 10% Carbon Comp Res LL	R214-475 **
T1, T2	I F Transformer	TB52-003
T5	DC Convertor	TC64-201
** T4	Power Transformer	TC648-01 **
T4	Power Transformer	TC65-401
Mobile Mounting Bracket	¼-20X½ HH Cad	U201-000
	6 X 3/8 Hex Washer Heads Ltd Type A C O	U222-000
	4X3/8 HWH 17 Type A Zinc or Cad	U231-000
Panel-Chassis	6X5/16 Phil Hd Type 25 Cad	U234-000
Wrap to Chassis	6X½ Slotted Hex W Hd Type A Black O	U242-000
	8X3/8 Holt Pan Hd Type BA Zinc OR	U251-000
	#4 Hex Washer Hd Type AB ½ Long Z,C or Blk. Ox.	U254-000
	Flexible Jumper	WA54-705
	Flexible Jumper	WA54-706
	Solid, #22, 300V 1/64 PVC, Fri Black	W100-000
	Solid, #22 300V 1/64 PVC Fri Brown	W101-000
	Solid, #22 300V 1/64 PVC Fri Red	W102-000
	Solid, #22 300V 1/64 PVC Fri Orange	W103-000
	Solid #22 300V 1/64 PVC Fri Yellow	W104-000
	Solid #22 300V 1/64 PVC Fri Green	W105-000
	Solid #22 300V 1/64 PVC Fri Blue	W106-000
	Solid #22 300V 1/64 PVC Fri Violet	W107-000
	Str. #18 16/30 600V 1/32 PVC Black	W600-000

** BC-250F (240 Volt)

PLACEMENTDESCRIPTIONELECTRA NUMBER

	Str. #18 16/30 600V 1/32 PVC Red Fri	W602-000
	Wire Buss 22 Ga	W922-000
CF3	Ceramic Filter	YA53-501
Y1	Crystal 133MHz	YA61-001
CF1, CF2	Crystal Filter	YA86-101
Y2	Crystal 10.4MHz 30 ohm	YA92-401

EM SCHEMATIC DIGEST
SHERMAN M. WOLF
BOSTON MASS.

3199 DE LION

LOOK FOR ILSE ST Helen
up all ways straight
Lights Last Light
Right Delion
straight

463-2873